

1015F13

Precious metal commutation

Applications: Security equipment, mini electronic products, remote control aerocrafts, personal caring products, portable tools and so on.

Characteristics

			14053
1	Voltage	V	1.5
2	Terminal resistance	Ω	0.9
3	No-load speed	rpm	17500
4	No-load current	mA	110
5	Stall torque	mNm	0.70
6	Stall current	mA	1688
7	Load torque	mNm	0.10
8	Load speed	rpm	15060
9	Load current	mA	330
10	Max. output power	W	0.32
11	Max. efficiency	%	32.3
12	Back-EMF constant	mV/rpm	0.08
13	Torque constant	mNm/A	0.45
14	Speed/torque gradient	rpm/mNm	24898
15	Varistor	Yes/No	Yes
16	Weight	g	3.9
17	Operating temperature range	$^{\circ}\text{C}$	-20~+80

Characteristics Curve

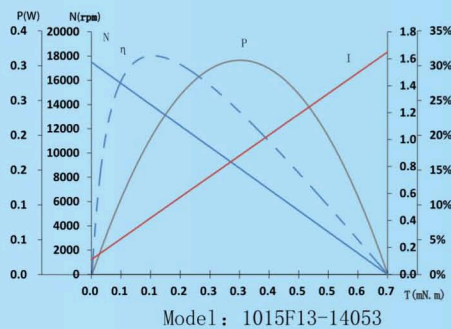

Options

- Lead wires length
- Shaft length
- Special coils
- Gearheads

Outline Drawing

ROTATION :CW

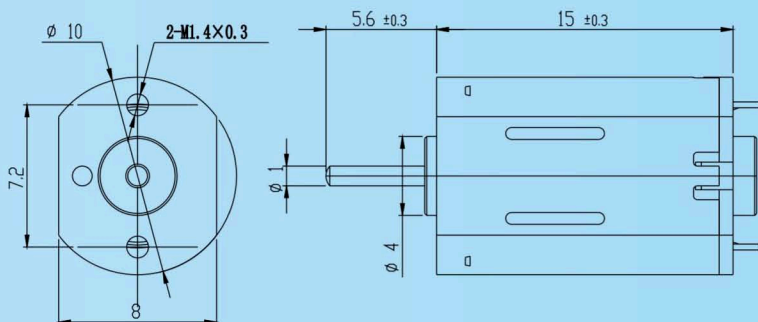

UNIT:mm