

2820ZWW

Outer Rotor Without Sensor

Applications: UAV, Aeromodelling, etc.

Characteristics

			-4-10.5	
1	Voltage	V	10.5	
2	Terminal resistance	Ω	0.13	
3	No-load speed	rpm	13500	
4	No-load current	A	0.45	
5	Nominal torque	mNm	74.2	
6	Nominal speed	rpm	11800	
7	Nominal current	A	10.5	
8	Max. output power	W	210	
9	Max. efficiency	%	86	
10	Back-EMF constant	mV/rpm	0.77	
11	Torque constant	mNm/A	7.4	
12	KV Value	rpm/V	1290	
13	Speed/torque gradient	rpm/mNm	22.8	
14	Rotor inertia	gcm ²	19	
15	Weight	g	41	
16	Thermal resistance housing-ambient	K/W	4.8	
17	Thermal resistance winding-housing	K/W	5.4	
18	Thermal time constant motor	s	280	
19	Thermal time constant winding	s	37	
20	Operating temperature range	°C	-40~+100	
21	Max. winding temperature	°C	155	
22	Axial play	mm	0.012	
23	Radial play	mm	0.008	
24	Axial load dynamic	N	5	
25	Axial load static	N	80	
26	Radial load at 3 mm from mounting face	N	29	
27	No. of pole pairs		7	
28	Bearings		2 ball bearings	
29	Commutation		Sensorless	
30	Protection class		IP 20	

Options

- Lead wires length
- Shaft length
- Special coils
- Gearheads
- Bearing type
- Encoder
- Driver

Outline Drawing

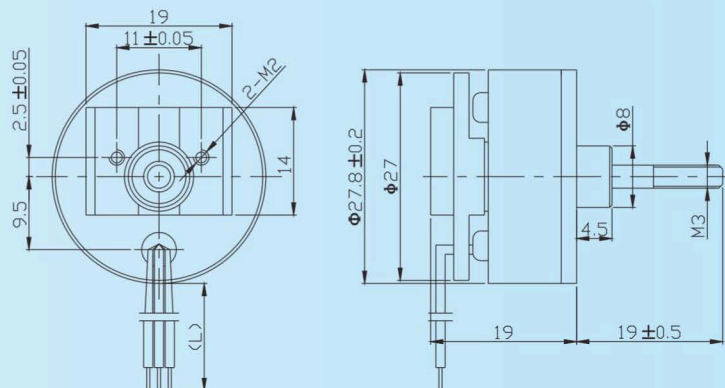

UNIT:mm