

Tutti i particolari costruiti devono essere esenti da eventuali bavure o spigoli vivi e puliti da residui di lavorazione (trucioli e lubrificanti)

F&C SOLUTIONS Srl
Via L. Grassi, 29
20056 Trezzo sull'Adda - Mi - Italy
Tel. +39 02-84103570 Fax +39 02-84103580
www.fcsolutions.it

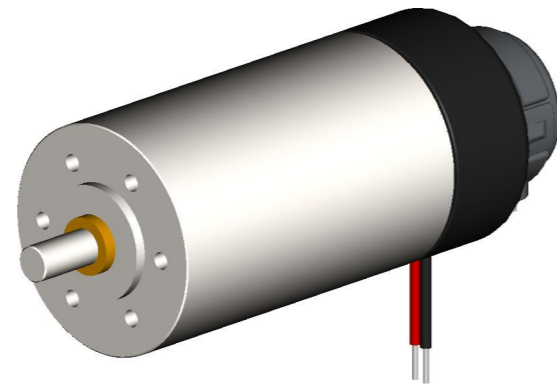
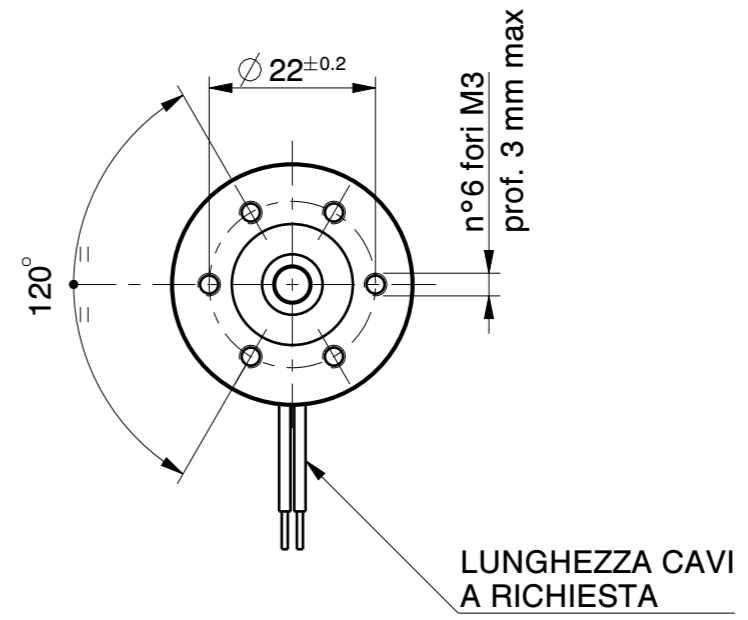
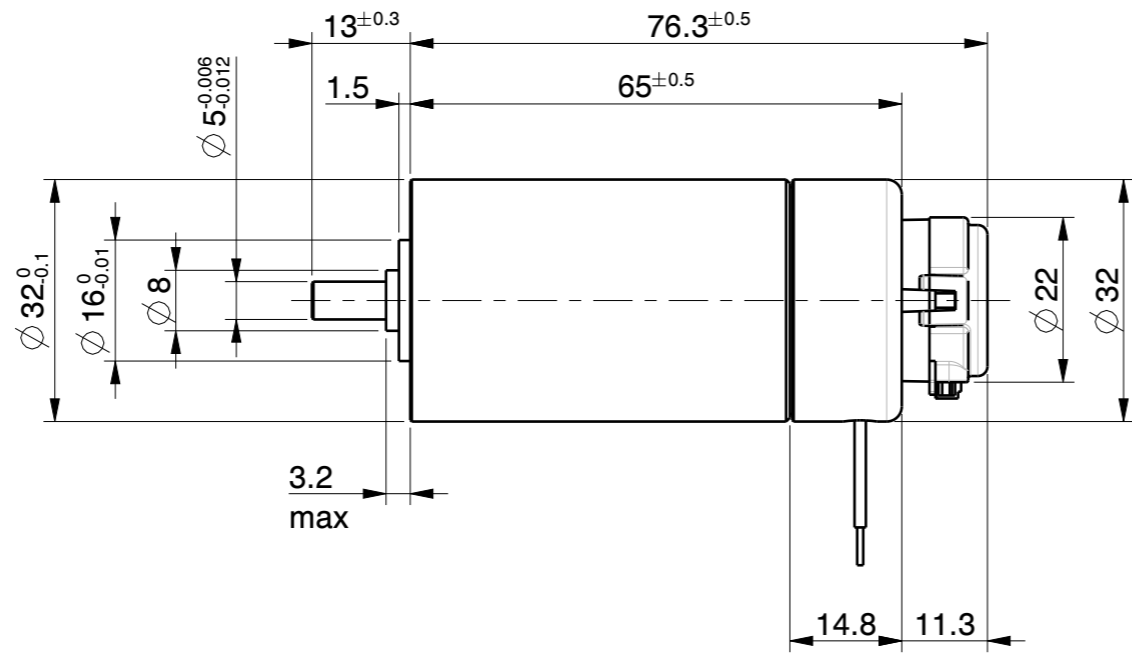

Rev.	Data/Date	Descrizione/Description	Nome/Name
Tolleranze/Tolerances UNI EN 22768-1		Q.ta/Q.ty	Next assy/Assieme suc.
Fine		Materiale/Material	Disegnato da/Drawing by
Media		Trattamento/Treatment and Coating	Data/Date
Grossolana			LB
Molto Grossolana			10.11.17
		Cliente/Cient	Approvato/Approved
		Modello/Model	LB
		Sostituisce il/Replaces the	Scala/Scale
			1:1
		Descrizione/Description	Foglio/Sheet
		MOTORE FC3257 + E4T	1/1
			Disegno n°/Drawing n°
			Rev.
			ASSY-MOTORE-3257

LA PROPRIETA' DI QUESTO DISEGNO E' RISERVATO A TERMINI DI LEGGE - ALL THE PROPERTY OF THIS TECHNICAL DRAWING IS RESERVED ACCORDING TO LAW RULES