

5540ZW

Outer Rotor With Sensor

Applications: Precision driving field in medical equipment, industrial automation, etc.

Characteristics

			-1-24.0	
1	Voltage	V	24	
2	Terminal resistance	Ω	0.42	
3	No-load speed	rpm	18400	
4	No-load current	A	0.53	
5	Stall torque	mNm	700	
6	Stall current	A	57	
7	Nominal torque	mNm	70	
8	Nominal speed	rpm	16500	
9	Nominal current	A	6.2	
10	Max. output power	W	337	
11	Max. efficiency	%	82	
12	Back-EMF constant	mV/rpm	1.3	
13	Torque constant	mNm/A	12.4	
14	KV Value	rpm/V	770	
15	Speed/torque gradient	rpm/mNm	26	
16	Rotor inertia	gcm ²	500	
17	Weight	g	210	
18	Thermal resistance housing-ambient	K/W	3	
19	Thermal resistance winding-housing	K/W	3.5	
20	Thermal time constant motor	s	180	
21	Thermal time constant winding	s	45	
22	Operating temperature range	°C	-40~+100	
23	Max. winding temperature	°C	155	
24	Axial play	mm	2.1	
25	Radial play	mm	0.008	
26	Axial load dynamic	N	10	
27	Axial load static	N	110	
28	Radial load at 3 mm from mounting face	N	42	
29	No. of pole pairs		2	
30	Bearings		2 ball bearings	
31	Commutation		Hall Sensor	
32	Protection class		IP 20	

Options

- Lead wires length
- Shaft length
- Special coils
- Gearheads
- Bearing type
- Hall sensor
- Encoder
- Driver

Outline Drawing

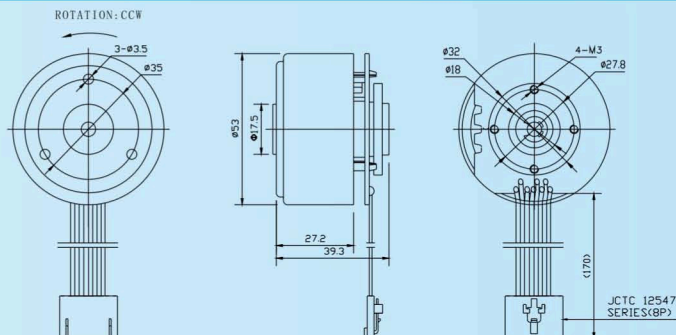

UNIT:mm