

**BMS 10-10      φ10 , 0.43 mNm      with Hall sensors**

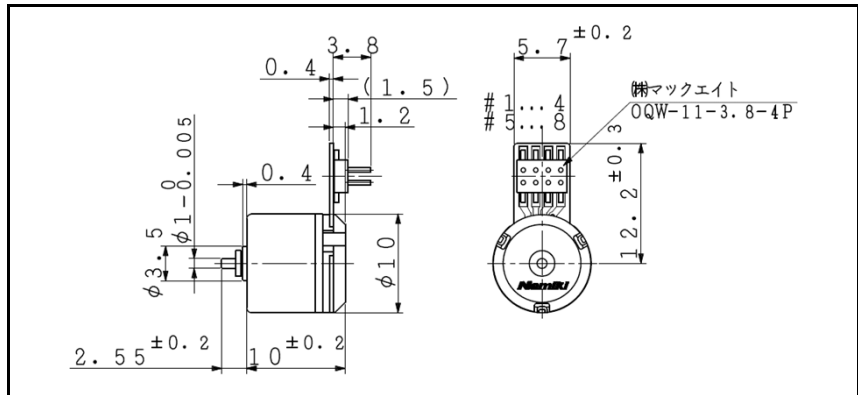
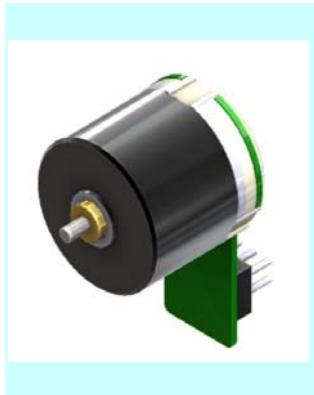

For combination with gearhead: SSG10, SPG10

Dimension in mm

Ordering number	BMS10-1003	BMS10-1007	
1 Nominal voltage	7.4	12.0	V
2 Rated torque	0.44	0.43	mNm
3 Rated speed	52300	55000	rpm
4 Rated current	812	544	mA
5 No load speed	71700	76300	rpm
6 No load current	300	210	mA
7 Stall torque	1.62	1.53	mNm
8 Stall current	2.20	1.41	A
9 Output power	1.6	1.5	W
10 Max. efficiency	40	38	%
11 Terminal resistance	2.90	7.35	Ω
12 Friction torque	0.26	0.27	mNm
13 Back-EMF constant	0.089	0.134	mV/rpm
14 Torque constant	0.85	1.28	mNm/A
15 Slope of N-T curve	38182	43019	rpm/mNm
16 Mechanical time constant	10.92	12.30	ms
17 Rotor inertia	0.03	0.03	gcm <sup>2</sup>
18 Max. torque	0.81	0.76	mNm

Mechanical data		
19 Shaft radial play	0.015	mm
20 Shaft axial play	0.23	mm
21 Max. shaft radial load	0.27 (3.7 mm)	N
22 Max. shaft axial load	0.1	N
23 Max. shaft axial load at standstill	10	N

Electrical connections (Terminal: OQW-11-3.8-4P/MAC8)		
#1	Hu	Hall sensor output U
#2	Hw	Hall sensor output W
#3	Hv	Hall sensor output V
#4	Vdd	Input voltage 3.0V
#5	Lw	Motor winding W
#6	Lv	Motor winding V
#7	Lu	Motor winding U
#8	Gnd	GND

Environmental specifications		
24 Operating temperature	-20 ~ 80	°C
25 Max. coil temperature	90	°C

Other specifications		
26 Weight	4	g

\*The characteristics are measured with our test driver.

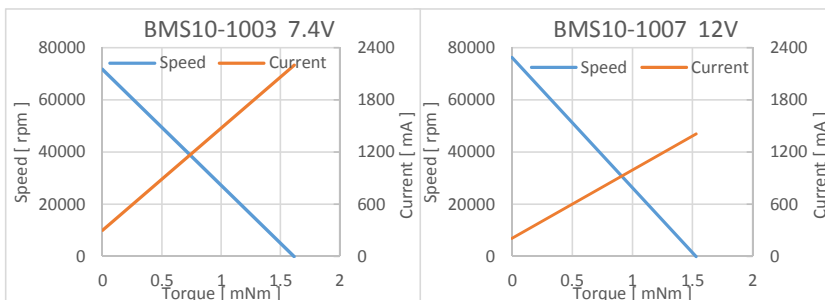

V01