

BMS 10-18 φ10 , 0.70 mNm with Hall sensors

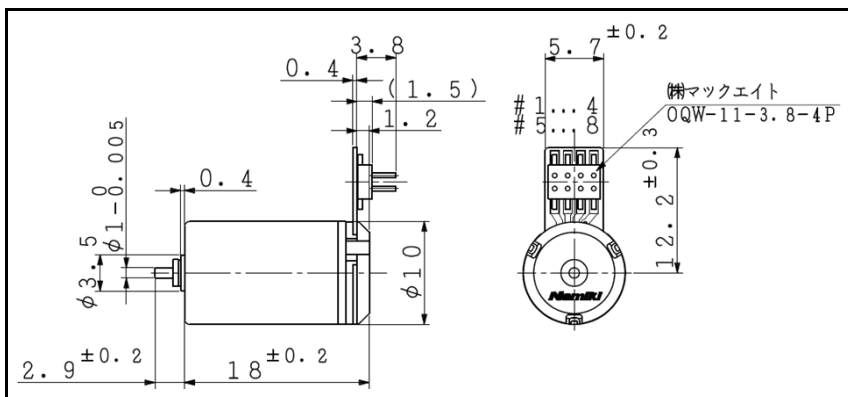
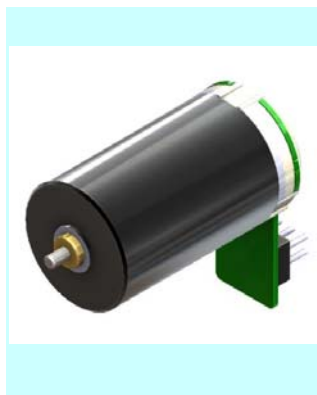

For combination with gearhead: SSG10, SPG10

Dimension in mm

Ordering number	BMS10-1802	BMS10-1806	
1 Nominal voltage	7.4	12.0	V
2 Rated torque	0.72	0.70	mNm
3 Rated speed	31600	32800	rpm
4 Rated current	474	304	mA
5 No load speed	37200	38900	rpm
6 No load current	84	56	mA
7 Stall torque	4.75	4.49	mNm
8 Stall current	2.66	1.64	A
9 Output power	4.7	4.5	W
10 Max. efficiency	68	66	%
11 Terminal resistance	2.39	6.33	Ω
12 Friction torque	0.16	0.16	mNm
13 Back-EMF constant	0.193	0.298	mV/rpm
14 Torque constant	1.84	2.84	mNm/A
15 Slope of N-T curve	6749	7468	rpm/mNm
16 Mechanical time constant	4.40	4.86	ms
17 Rotor inertia	0.06	0.06	gcm ²
18 Max. torque	2.37	2.25	mNm

Mechanical data		
19 Shaft radial play	0.015	mm
20 Shaft axial play	0.23	mm
21 Max. shaft radial load	0.27 (3.7 mm)	N
22 Max. shaft axial load	0.1	N
23 Max. shaft axial load at standstill	10	N

Environmental specifications		
24 Operating temperature	-20 ~ 80	°C
25 Max. coil temperature	90	°C

Other specifications		
26 Weight	7.2	g

Electrical connections (Terminal: OQW-11-3.8-4P/MAC8)

#1	Hu	Hall sensor output U
#2	Hw	Hall sensor output W
#3	Hv	Hall sensor output V
#4	Vdd	Input voltage 3.0V
#5	Lw	Motor winding W
#6	Lv	Motor winding V
#7	Lu	Motor winding U
#8	Gnd	GND

*The characteristics are measured with our test driver.

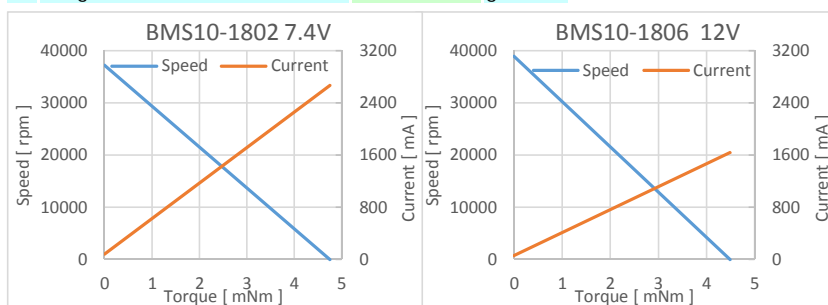

V01