

EHM10-3B

3 Channels magnetic incremental encoder

Preliminary Specification

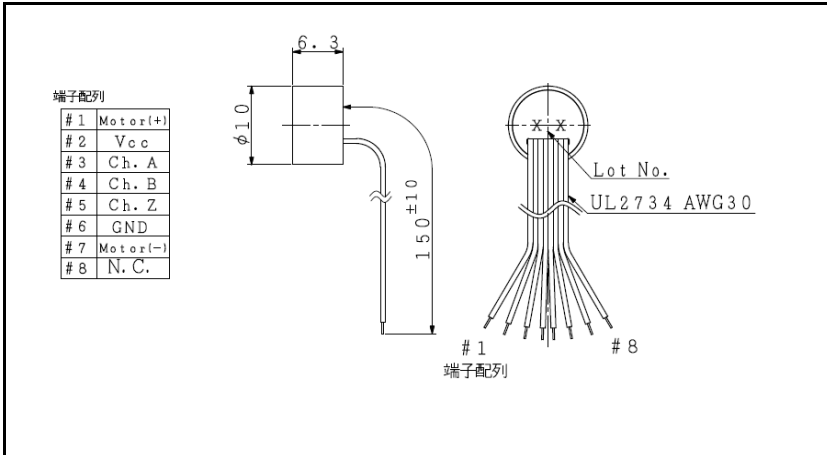

Output circuit

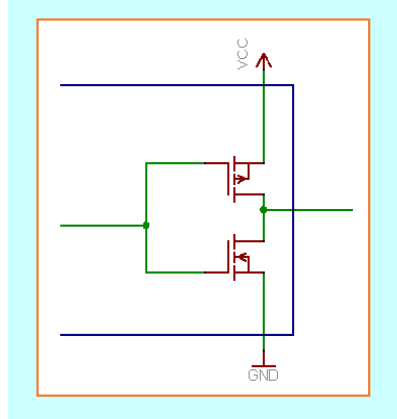

Specification at 25°C

	EHM10-3B	
1 Sensor	Magnetic	
2 Encoder Type	Incremental	
3 Output Signal	TTL compatible	
4 Number of Channels	3	channel
5 Resolution (Max. speed = 50,000 rpm)	64	pulse/rev
6 Max. Frequency Response	55	kHz
7 Supply Voltage, V _{CC}	4.5 . . . 5.5	V
8 Supply Current, typical	14	mA
9 Output Voltage "H"	≥ 2.4 (Max. V _{CC})	V
10 Output Voltage "L"	≤ 0.4	V
11 Output current per channel	4.0	mA
12 Rise and fall time (R _L = 2.7 kΩ and C _L = 25 pF), typical	Tr = 60, Tf = 60	ns
13 Inertia	TBD	gmm ²
14 Operating Temperature	-20 . . . +85	°C
15 Storage Temperature	-20 . . . +85	°C

Output signal (at motor shaft clockwise rotation)

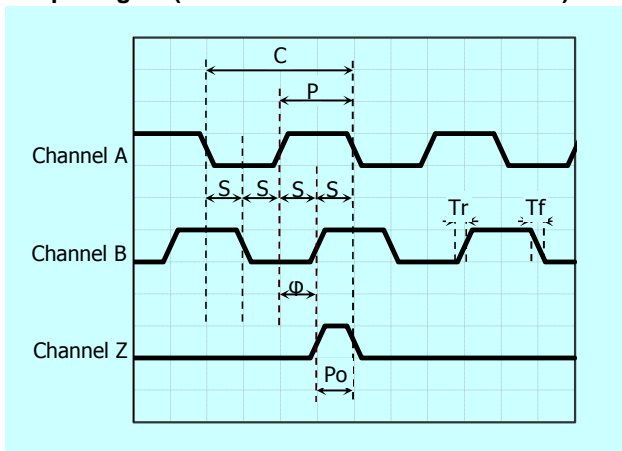

Output signal information

Cycle C	360	°e
Pulse P	180	°e
A to B channel phase shift, φ	90±45	°e
Logic state width, S	90±45	°e
Z channel width, Po	90±45	°e

*Maximal error (±°e) indicated above.

Electrical connections

#1	(MOTOR+)	(Motor winding)
#2	V _{CC}	DC4.5...5.5V
#3	Ch.B	TTL compatible
#4	Ch.A	TTL compatible
#5	Ch.Z	TTL compatible
#6	GND	
#7	(MOTOR-)	(Motor winding)
#8	—	NC

V01

Adamant Namiki Precision Jewel Co.,Ltd

Specifications subject to change without notice

TEL: 03-5390-7620 FAX: 03-5390-8082

URL: www.ad-na.com/en/

E-mail: motor-sales@namiki.net