

## Description

The **MAE3** is an absolute magnetic kit encoder that provides shaft position information over 360 ° of rotation with no stops or gaps. This magnetic encoder is designed to easily mount to, and dismount from, an existing shaft to provide digital feedback information. The **MAE3** is available with an analog or a pulse width modulated (PWM) digital output.

Analog output provides an analog voltage that is proportional to the absolute shaft position. Analog output is only available in 10-bit resolution.

PWM output provides a pulse width duty cycle that is proportional to the absolute shaft position. PWM output is available in 10-bit and 12-bit resolutions. While the accuracy is the same for both encoders the 12-bit version provides higher resolution.

The **MAE3** consists of three components: base, push-on magnetic hub, and encoder body. The base will accommodate 0.750", 1.280" and 1.812" mounting bolt circles. No tools are needed for the push-on, collet gripping hub. The hub mounts to a standard shaft in seconds and provides a simple and reliable means of securing the magnet to the shaft.

Two 4-40 pan head screws secure the base and encoder body to any flat surface. If desired, the encoder can be powered up and rotated by hand to any desired absolute position before the screws are tightened.

Connecting to the **MAE3** is simple. The 3-pin, high retention, snap-in 1.25mm pitch polarized connector provides for +5V, output, and ground.



## Features

- ▶ Quick, simple assembly and disassembly
- ▶ -40C to +125C operating temperature
- ▶ Accepts ± .025" axial shaft play
- ▶ Mounts to 0.750", 1.280" and 1.812" bolt circles
- ▶ Fits shaft diameters from .125" to .250" or 2mm to 6mm
- ▶ 10-bit Analog output - 2.6 kHz sampling rate
- ▶ 10-bit PWM output - 1024 positions per revolution, 1 kHz
- ▶ 12-bit PWM output - 4096 positions per revolution, 250 Hz

### Mechanical Drawing

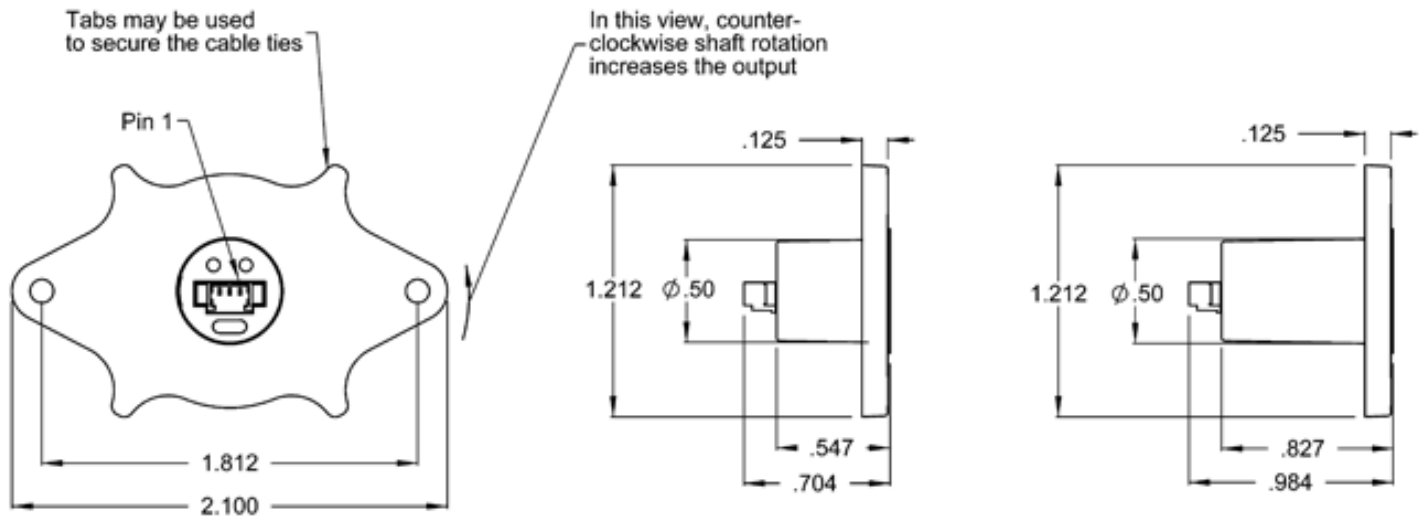

### Environmental

Parameter	Value	Units
Operating Temperature	-40 to +125	C
Vibration (5Hz to 2kHz)	20	G
Electrostatic Discharge, Human Body Model MIL-STD-883E, Method 3015.7	$\pm 2$	kV

### Mechanical

Parameter	Value	Units
Max. Shaft Axial Play	$\pm 0.025$	in.
Max. Shaft Total Indicated Runout (1)	0.004	in.
Max. Acceleration	250000	rad/sec <sup>2</sup>
Moment of Inertia	$8.49 \times 10^{-7}$	oz-in-s <sup>2</sup>
Mounting Screw Size (pan head)	4-40 x 1/4"	-
2 Screw Bolt Circle Diameter	$0.750 \pm .005$	in.
2 Screw Bolt Circle Diameter	$1.280 \pm .005$	in.
2 Screw Bolt Circle Diameter	$1.812 \pm .005$	in.
Required Shaft Length, including axial play (1)		
<b>Size 220 Shaft Length</b> -option	0.220 (+0.015 / -0.020)	in.
<b>Size 500 Shaft Length</b> -option	0.500 (+0.015 / -0.020)	in.
Base to Mounting Surface Torque	4 - 6	in-lbs

Parameter	Value	Units
Shaft diameter tolerance, relative to nominal	-0.0001 to -0.0006	in.
Technical Bulletin TB1001 - Shaft and Bore Tolerances		Download

(1) For optimum accuracy, the magnetic hub must be fully seated on the shaft and the shaft play must meet the specified axial and radial limits.

(2) The chip that decodes position uses sampled data. There will be fewer readings per revolution as the speed increases. The formula for number of readings per revolution is given by:

**10-bit PWM:**

$$n = 625200 / \text{rpm}$$

**12-bit PWM / Analog:**

$$n = 156600 / \text{rpm}$$

 **Electrical**

Parameter	Min.	Typ.	Max.	Units
Power Supply	4.5	5.0	5.5	Volts
Supply Current	-	16	20	mA
Power-up Time	-	-	50	mS

 **Analog Output Operation**

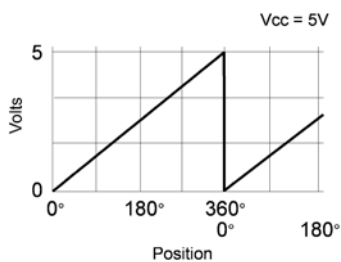

Analog output is only available in 10-bit resolution. The analog output voltage is ratiometric to the power supply voltage and will typically swing within 15 millivolts of the power supply rails with no output load. This non-linearity near the rails increases with increasing output loads. For this reason, the output load impedance should be  $\geq 4.7k\Omega$  and less than 100pF. The graphs below show the typical output levels for various output loads when powered by a 5V supply.

Parameter	Min.	Typ.	Max.	Units
Position Sampling Rate	2.35	2.61	2.87	kHz
Propagation Delay	-	-	384	?S

Parameter	Min.	Typ.	Max.	Units
Analog Output Voltage Maximum (1)	-	4.987	-	Volts
Analog Output Voltage Minimum (1)	-	0.015	-	Volts
Output Short Circuit Sink Current (2)	-	32	50	mA
Output Short Circuit Source Current (2)	-	36	66	mA
Output Noise (2)	160	220	490	$\mu$ Vrms
Output Transition Noise (3)	-	0.03	-	Deg. RMS

(1) With no output load. See graphs below.

(2) Continuous short to +5V or ground will not damage the MAE3.

(3) Transition noise is the jitter in the transition between two adjacent position steps.

Output Voltage vs. Output Load w/ Pulldown Resistors to GND

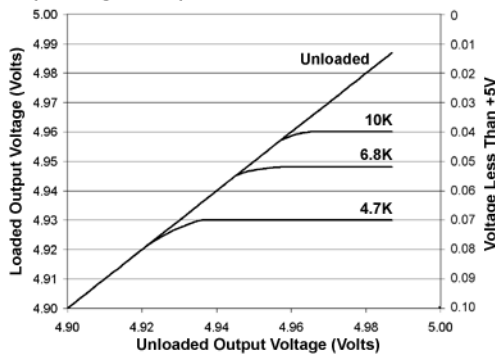

Output Voltage vs. Output Load w/ Pullup Resistors to +5V

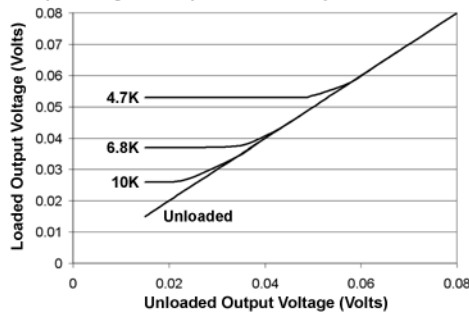

## PWM Output Operation

The magnetic sensor chip in the MAE3 has an on-chip RC oscillator which is factory trimmed to 5% accuracy at room temperature (10% over full temperature range). This tolerance influences the sampling rate and the pulse period of the PWM output. If only the PWM pulse width  $t_{on}$  and nominal pulse period is used to measure the angle, the resulting value also has this timing tolerance. However, this tolerance can be cancelled by measuring both  $t_{on}$  and  $t_{off}$  and calculating the angle from the duty cycle.

Parameter	Min.	Typ.	Max.	Units
-----------	------	------	------	-------

PWM Frequency (-40C to 125C)				
10-bit	0.877	0.975	1.072	kHz
12-bit	220	244	268	Hz
Minimum Pulse Width				
10-bit	0.95	1.00	1.05	uS
12-bit	0.95	1.00	1.05	uS
Maximum Pulse Width				
10-bit	974	1025	1076	uS
12-bit	3892	4097	4302	uS
Internal Sampling Rate				
10-bit	9.38	10.42	11.46	kHz
12-bit	2.35	2.61	2.87	kHz
Propagation Delay				
10-bit	-	-	48	uS
12-bit	-	-	384	uS
Output Transition Noise, 12-bit version (1)		.03		Deg. RMS
Output Transition Noise, 10-bit version (1)		.12		Deg. RMS
Output High Voltage (VOH: @4mA Source) (2)		Vcc -0.5	-	V
Output Low Voltage (VOL: @4mA Sink) (2)		-	0.4	V

(1) Transition noise is the jitter in the transition between two adjacent position steps.

(2) Continuous short to +5V or ground will not damage the MAE3.

### 10-bit PWM:

$$x = ((t_{on} * 1026) / (t_{on} + t_{off})) - 1$$

If  $x \leq 1022$ , then Position =  $x$

If  $x = 1024$  then Position = 1023

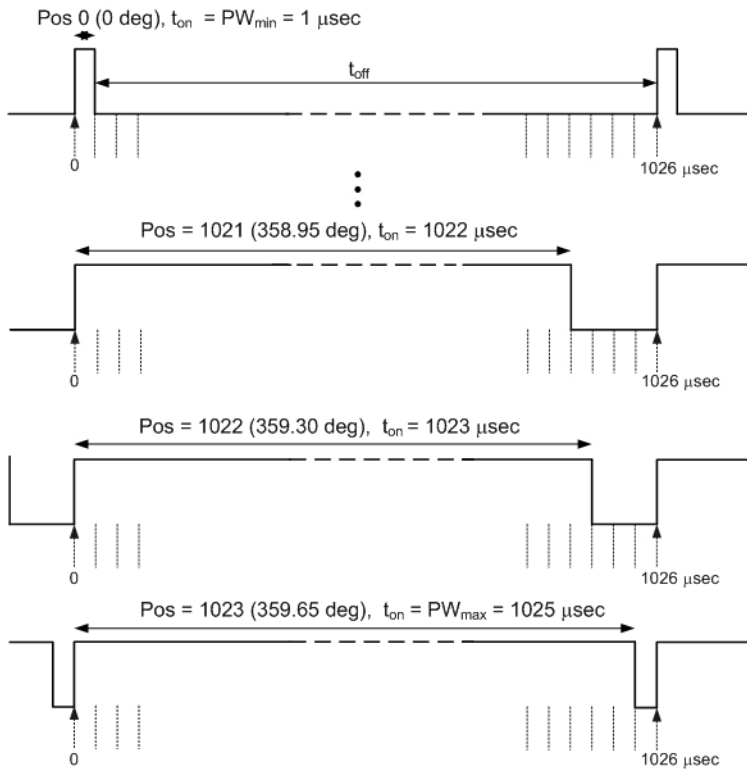

**12-bit PWM:**

$$x = ((t_{on} * 4098) / (t_{on} + t_{off})) - 1$$

If  $x \leq 4094$ , then Position =  $x$

If  $x = 4096$  then Position = 4095

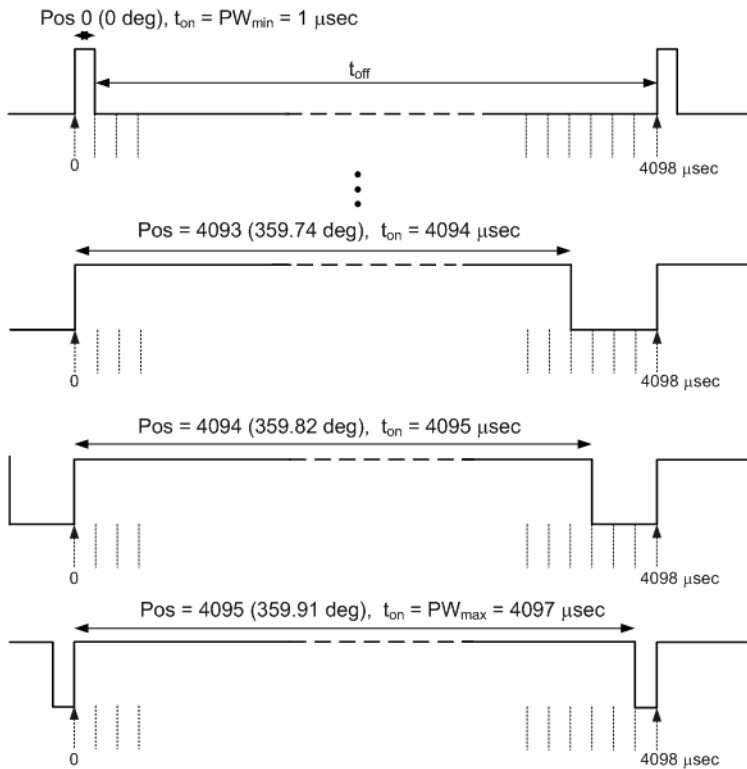

### Pin-outs

#### Analog Output (MAE3-A):

Pin	Name	Description
1	5	+5VDC power
2	A	Analog output
3	G	Ground

#### PWM Output (MAE3-P10, MAE3-P12):

Pin	Name	Description
1	5	+5VDC power
2	A	PWM output
3	G	Ground

### Accessories

#### Screws

Part #:	SCREW-440-250-PH
Description:	4-40 x 1/4" Pan head screw
Quantity Required for Mounting	2 per encoder

## Assembly Instructions

MAE3 Assembly Instructions - <http://usdigital.com/assets/general/MAE3%20Assembly%20Instructions.pdf>

## Ordering Information

MAE3 -		-		-		-		-	
<b>Interface</b>	<b>Bore</b>	<b>Shaft Length</b>	<b>Bolt Circle</b>	<b>Packaging</b>					
A10 = 10-Bit Analog	118 = 3mm	220 = 0.220"	7 = 0.750"	B = Encoder components packaged in bulk.					
P10 = 10-Bit PWM	125 = 1/8"	500 = 0.500"	12 = 1.280"	1 = Each encoder packaged individually					
P12 = 12-Bit PWM	157 = 4mm		18 = 1.812"						
	188 = 3/16"								
	197 = 5mm								
	236 = 6mm								
	250 = 1/4"								

## Notes

- Cables and connectors are not included and must be ordered separately.
- US Digital® warrants its products against defects in materials and workmanship for two years. See complete warranty for details.